

**2017 ISSA, ICSA Singlehanded National Championships  
LASERPERFORMANCE CONDITIONS OF CHARTER**

**NAME** \_\_\_\_\_

**HULL NO** \_\_\_\_\_

[ ] Laser Standard [ ] Laser Radial

**TERMS OF CHARTER**

1. Boats will be supplied with spars, hull, foils, sail, running rigging and dolly.
2. A compass, wind indicator and sail tell tales supplied by the competitor may be used provided that they can be fitted without piercing or otherwise marking the hull, or spars.
3. Wet or dry sanding of the hulls or any other equipment is prohibited
4. The use to waxes, polishing compounds or similar is prohibited. Competitors may wash their boat with detergent and water.
5. Plastic tape or similar may be used in accordance with the Class Rules.
6. All the masts have been checked to make sure they are within the design tolerance. Competitors are reminded that masts may be more likely to bend if high boom vang loadings are used.
7. Damage deposits are not required, instead, competitors must provide valid credit card information, which will be used to cover any costs due to damaged or replaced equipment during and after the event.
8. Charter boats are insured for third party liability. The cost of any damage, including scratches and bent spars, will be charged to the credit card supplied.
9. Any damage or loss of equipment to a charter boat, no matter how slight, must be reported to the LaserPerformance representative at the completion of the race in which it occurs.
10. Responsibility for damage to boats or to other property will be determined under the racing rules and all contestants will be bound thereby.
11. Charterer (competitor) is solely responsible for any cost of damage or repairs regardless of fault.
12. Any competitor found towing at more than 5kts will be charged \$500 and have the equipment withdrawn immediately
13. No fitting may be removed, even if it is subsequently replaced, and no repairs may be undertaken without the permission of the Organizing committee. Note: all the fittings are sealed with silicone during manufacture.
14. Competitors are not covered by any insurance provided by LaserPerformance, and should have or seek their own coverage for personal goods and liability. At-fault occurrences to other boats are the responsibility of the skipper.
15. The use of the charter boat may be withdrawn if, in the sole opinion of the Organizing Committee, a competitor breaks any of the conditions of charter or treats or handles a charter boat without care or in a manner which causes or is likely to cause damage to the boat.

**\*\*RETURNS\*\***

16. 17. CHARTEREE IS RESPONSIBLE FOR ASSISTING THE LOAD UP UNLESS OTHERWISE DIRECTED BY THE LASERPERFORMANCE REPRESENTATIVE. Failure to do so could result in extra charges.
17. 18. Boats AND dollies must be washed with fresh water, sand/grass removed from hull, deck and cockpit. Failure to do so could result in extra charges.

**I accept a charter boat in good condition and understand and agree to abide by the conditions of charter as detailed above.**

Name (printed) \_\_\_\_\_ Name(signed) \_\_\_\_\_ Date \_\_\_\_\_

Institution \_\_\_\_\_

Parent or guardian if under 18 (signed) \_\_\_\_\_ Date \_\_\_\_\_



**CREDIT CARD INFORMATION** -----

Name as it appears on card \_\_\_\_\_ Phone \_\_\_\_\_

Card Type [VISA] [MASTERCARD] \_\_\_\_\_ Email \_\_\_\_\_

Card Number \_\_\_\_\_ CVC (3-digit code) \_\_\_\_\_ Exp. Date \_\_\_\_\_

**Notice – Fixed Fee Repairs**

**Repairs**

The cost of repair is \$95 per hour; this is excluding costs for materials or replacement parts. Replacement parts will be charged at the full local retail price.

**What is a light / deep / major scratch?**

**Light scratch:**

Damage that will require sanding and polishing, this will normally be caused by hiking pants, tillers, tiller extensions and minor collisions with other boats.

**Deep scratch:**

Damage that requires gel coat work on the hull or filling work on the foils.

**Major Scratch / repair needed:**

Damage that requires more than just gel coat or simple filling on foils; i.e. glass repair on the hull or major parts of the foils missing.

<b>Type of Damage and charge for single repair</b>	<b>Price</b>
Hiking Pant / Tiller Extension Marks on hull, requiring only sanding and polishing	<b>\$15</b>
Hiking Pant / Tiller Extension Marks on hull, requiring gel coat work	<b>\$45</b>
Small broken foil tips	<b>\$15</b>
Large broken foil tips	<b>\$30</b>
Light scratches to hull (hull/transom area is at risk during launch/recovery)	<b>\$25</b>
Deep scratches to hull (hull/transom area is at risk during launch/recovery)	<b>\$40</b>





Hull Number: .....  
 Name: .....  
 Date: .....

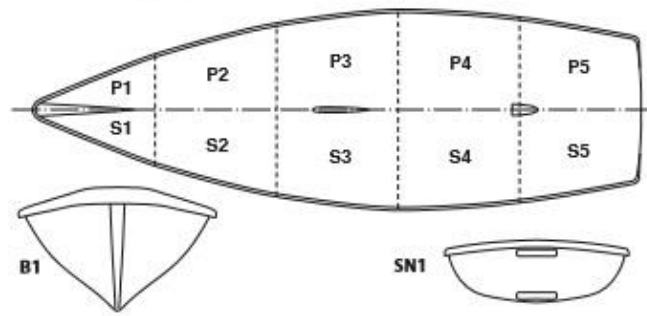

HULL	OK	Charge
P1	<input type="checkbox"/>	_____
P2	<input type="checkbox"/>	_____
P3	<input type="checkbox"/>	_____
P4	<input type="checkbox"/>	_____
P5	<input type="checkbox"/>	_____
S1	<input type="checkbox"/>	_____
S2	<input type="checkbox"/>	_____
S3	<input type="checkbox"/>	_____
S4	<input type="checkbox"/>	_____
S5	<input type="checkbox"/>	_____
B1	<input type="checkbox"/>	_____
SN1	<input type="checkbox"/>	_____
Anything else	<input type="checkbox"/>	_____

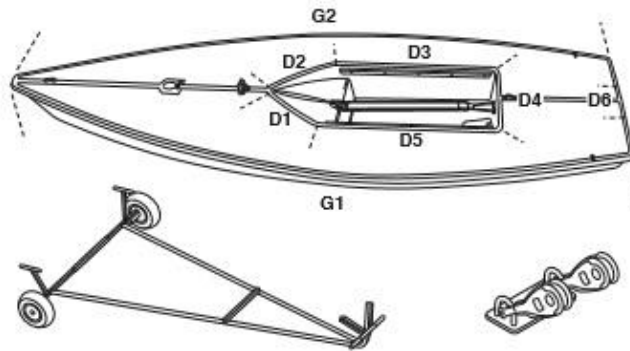

DECK	OK	Charge
D1	<input type="checkbox"/>	_____
D2	<input type="checkbox"/>	_____
D3	<input type="checkbox"/>	_____
D4	<input type="checkbox"/>	_____
D5	<input type="checkbox"/>	_____
D6	<input type="checkbox"/>	_____
G1	<input type="checkbox"/>	_____
G2	<input type="checkbox"/>	_____
Hiking strap	<input type="checkbox"/>	_____
Hiking strap rope	<input type="checkbox"/>	_____
Hiking strap elastic	<input type="checkbox"/>	_____
Mainsheet block	<input type="checkbox"/>	_____
Spring	<input type="checkbox"/>	_____
Deck blocks x2	<input type="checkbox"/>	_____
Anything else	<input type="checkbox"/>	_____
Trolley	<input type="checkbox"/>	_____

**OPTIONAL**

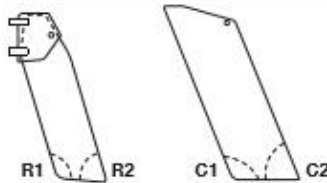

RUDDER	OK	Charge
R1	<input type="checkbox"/>	_____
R2	<input type="checkbox"/>	_____
Anything else	<input type="checkbox"/>	_____
C'BOARD		
C1	<input type="checkbox"/>	_____
C2	<input type="checkbox"/>	_____
Anything else	<input type="checkbox"/>	_____



Upper mast	<input type="checkbox"/>	_____
Lower mast	<input type="checkbox"/>	_____
Boom	<input type="checkbox"/>	_____



Cockpit bung	<input type="checkbox"/>	_____
Transom bung	<input type="checkbox"/>	_____

**TOTAL DEDUCTIONS** \_\_\_\_\_

Signature \_\_\_\_\_

= Light scratch     = Deep scratch     = Major scratch/repair needed

Total deductions: \_\_\_\_\_ LP Representative Initial: \_\_\_\_\_

Signature: \_\_\_\_\_ Date: \_\_\_\_\_

